



natural stone

SANDSTONE COLLECTION

marshalls.co.uk/naturalstone

Marshalls
Creating Better Spaces



Marshalls was founded in the 1890s when Solomon Marshall first quarried and produced Cromwell Yorkstone from the hillside at Southowram.

Since then, Marshalls has developed into the country's leading supplier of natural stone, as well as commercial hard landscaping products, linear drainage and street furniture. The experience gained from those early days has enabled Marshalls to evolve and adapt to meet customer needs, becoming the most innovative and exciting stone supplier in the country.



Added Value
Marshalls' natural stone range combines breadth of choice with a reliable, low risk supply chain.

Marshalls are the UK's premier manufacturer and distributor of natural stone products for the built environment.

As well as a broad range of indigenous UK stone, Marshalls offers materials that have been carefully selected via our long-established network of international stone partners. All overseas stone is responsibly sourced through a robust, proven supply chain, independently audited to ensure our high standards of ethical compliance and best practice are maintained.

When it comes to stone selection, Marshalls' experience in helping achieve exceptional projects is linked to a broad knowledge of stone, combined with an appreciation for the performance requirements and aesthetic touches needed to achieve brilliant results. With a range of stones and granites from Iberia, Vietnam and China and India, Marshalls have the portfolio of products to achieve any designer's vision for their space.

Marshalls' in-house experts can offer advice on selection and assist with value engineering, and have the capability to offer bespoke design and production, even including advanced artwork techniques such as embossing, water-jet work and inlaying.

As owners of the largest fleet of crane offload vehicles in the UK we can also offer complete site flexibility in even the most demanding of environments and time sensitive programmes.



TENDER

- Dedicated staff offer support and pricing
- Technical advice and value engineering
- Industry leading supply chain transparency offered, from audit reports through to quarry and production visits



MANUFACTURE

- State of the art production capabilities offer true flexibility and design freedom
- Dedicated quality control both in the UK and abroad
- Recognised as the most sustainable, best practice-driven UK stone supplier

SELECTION & DESIGN

- Our UK quarry portfolio offers a palette of British stone for designers to engage with
- Proven, independently audited supply chains offer low-risk access to the global stone market
- Fully tested technical performance data, CE marks and case studies available
- Design Service offers support including CAD and BIM



ON SITE

- Ownership of vehicle fleet offers unmatched on-site flexibility
- Marshalls fleet offers full UK coverage for consistent, low risk logistics
- Dedicated project ownership at Marshalls for consistent site liaison

Ethical Procurement & ERI

At Marshalls we are committed to consistent supply of the very best quality natural stone, purchased to the very highest standards of ethical best practice.



QUALITY

At Marshalls all our own quarries and stone production facilities carry not only the international mark of Quality ISO9001 but also the International Environmental ISO14001 accreditation and the ISO18001 accreditation for Health & Safety. From our other stone suppliers we demand a commitment to the quality of both production and also of materials. Marshalls has its own locally based inspectors on the ground who ensure that consistency and quality are at the heart of everything we do.

ETHICAL

Our commitment to the ethical sourcing of natural stone from abroad is regarded as exemplary. Not only have key people from Marshalls provided leadership at the Ethical Trading Initiative (ETI) but we are the only construction sector signatory to the UN Global Compact which relates to ethical standards. We have BES6001 certification for responsible sourcing, and were the first company in the world to be awarded BES6002 for ethical labour sourcing. To monitor our activity in sustainability, please visit www.marshalls.co.uk/sustainability and view our United Nations Global Compact "Communication on Progress".

ENVIRONMENTAL

All Marshalls own quarries and production facilities have environmental accreditation to ISO14001. Further to that we have undertaken the largest single carbon footprinting of construction products in the world with over 3,000 individual products being carbon footprinted. All our Yorkstones, sandstones and granite are all carbon footprinted so that any choices of material can be understood and assessed in regards to the effect on the environment.

WORKING WITH OUR SUPPLY CHAIN

At Marshalls we work with our suppliers to improve the standards of materials, production and worker's conditions continually. Our suppliers are chosen for their commitment to quality, consistency and ethics as well as their knowledge and versatility. Designers and contractors need confidence in their supplier and we are committed to achieving a seamless service regardless of where the materials come from.

THE ETHICAL RISK INDEX

The Marshalls Ethical Risk Index (ERI) is the next step on the journey toward full supply chain transparency in the Natural Stone sector. Using a bespoke framework built on independent audits, customers are given a genuine insight into the multi-dimensional ethical challenges facing stone procurers; with the aim of apprising users of potential issues and with a clear rating system to allow for more informed decision making.

MARSHALLS ETHICAL RISK INDEX

Scoring the ERI begins with an analysis at the Country-level, utilising various publicly available NGO-driven frameworks. From this, independent auditors, engaged to examine Marshalls supply chain, establish a baseline expectation of the cultural paradigm in that country. They can then delve into the supply chain and assess Marshalls' stone quarrying and processing operations; also contrasting it against the quarries and manufacturers supplying stone products to the wider stone industry. Thus the final ERI score for each stone type is always contrasted against the non-Marshalls supply chains for that material.

To illustrate the relative level of ethical risk, the Ethical Risk Index score is initially displayed using a basic Risk Indicator. This provides a quick, simple insight into the degree of ethical risk associated with that stone type, and how the Marshalls supply chain compares to the cluster. If users require a more in-depth perspective, they can access the Ethical Radar which clearly displays the scoring for that product against each of the 10 measures making up the ERI score.

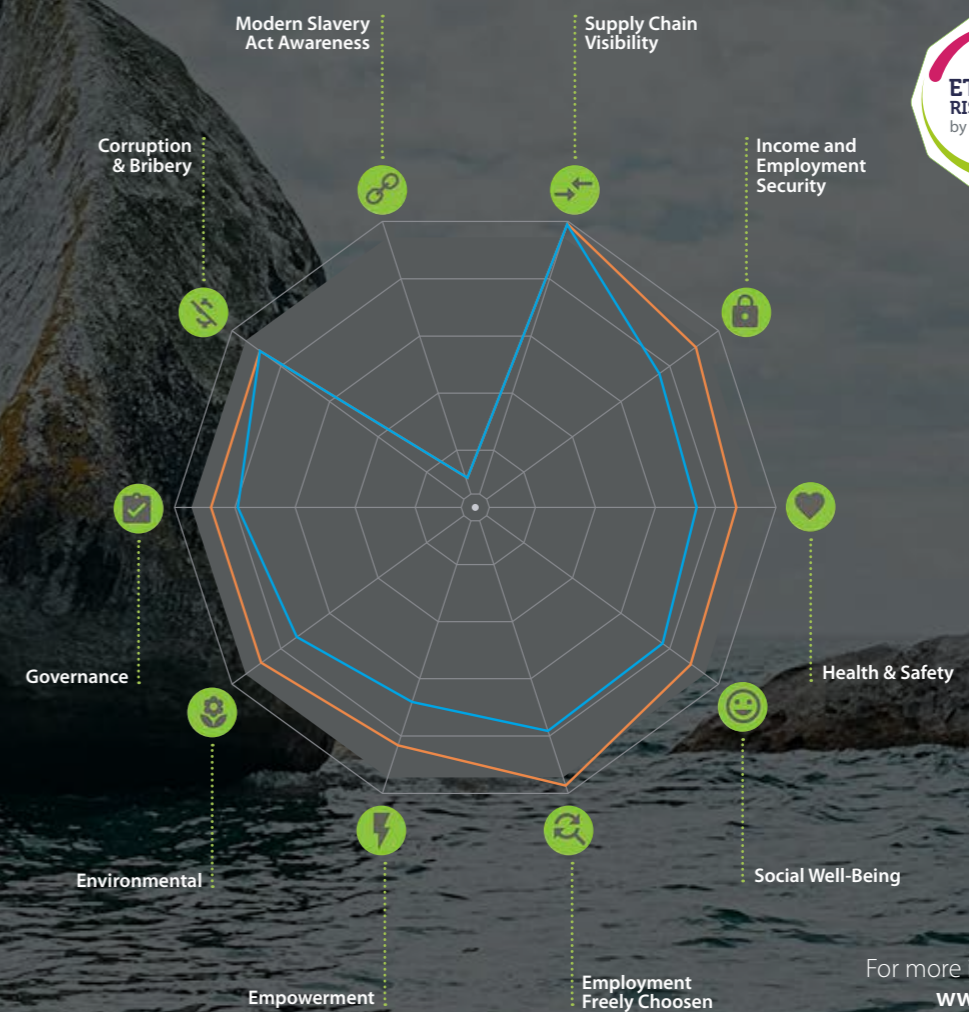

For more information, please visit www.marshalls.co.uk/eri

Inspire with artwork

The difference between a good project and a truly memorable project is often in the detail. Those design flourishes that can inspire the viewer, or perhaps help them learn more about the history of the locale.

Stone is endlessly versatile, with our skilled masons able to use classic techniques and the latest technology to create works of art. From advanced water-jet production, to traditional hand finishing and inlaying, designers specifying stone can be more ambitious than ever when visualising compelling new spaces.



Angel Court, London

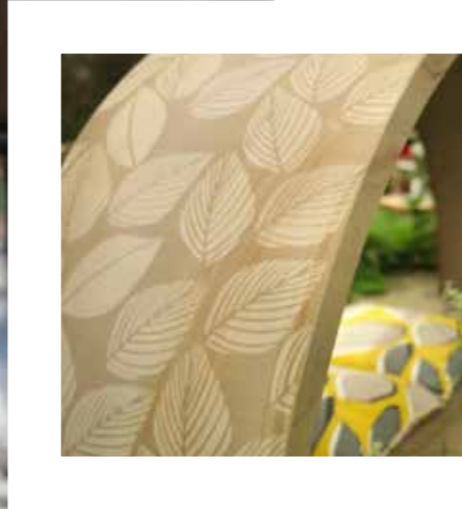

Inspire with design

Sandstone is a durable material which can be fashioned into a wide range of landscape products and despite its reputation as a traditional solution, can be used to provide a modern aesthetic if required. All of Marshalls' sandstones are available in at least paving and setts although most can be used to create special features.

Marshalls work on bespoke projects from initial concept design through to intricate detailing. With every element sourced, tailored or created around project vision, our theoretical and practical understanding of urban space is unrivalled.

Whether it's Scoutmoor Yorkstone step units with LED under lighting, or a curved bench to complement the architecture of a public space, Marshalls can turn your design ideas into reality.

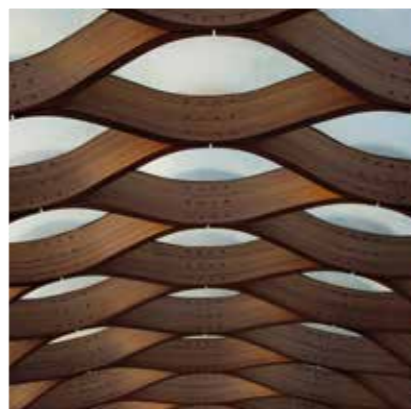

Bespoke Courtyard, York

National Memorial Arboretum | Staffordshire

INSPIRE with DESIGN

CASE STUDY

As part of a new £15.7 million development of a remembrance centre at the National Memorial Arboretum in Alrewas, Staffordshire, Marshalls was approached to supply a traditional looking hard landscaping solution.

Situated on the edge of the National Forest, the Arboretum is the UK's year-round centre of Remembrance, with a maturing woodland landscape that is home to over 330 memorials.

A £12 million appeal was launched in 2009 by HRH the Duke of Cambridge, the Patron, to rebuild the visitor centre so that those visiting the Arboretum would be able to enjoy outstanding facilities.

In the middle of this stunning new development, a courtyard called Heroes' Square was proposed. To help fund the project, an appeal offered a number of paving stones that would be intricately inscribed with cap badges or crests of the Royal Navy, the British Army, the Royal Air Force and City Livery Companies. Designed by the award-winning Fira landscape architect practice, the space delicately blends different material types and soft landscaping.

The new building's Portland limestone façade suggested a natural collaboration with Marshalls' Scoutmoor Natural Stone paving, a combination used throughout the streets of London.

Scoutmoor Yorkstone is exceptionally hardwearing and has beautiful natural colour variation. The blue grey and brown hues of the stone integrated well with the surrounding landscape, and perfectly coordinated with the larch timber used in the building's structure.



Inspire with blends

From warm creams and buffs, through to a wide variety of reds and pinks, the colour spectrum of our sandstone offers designers the opportunity to tell a unique story.

Marshalls' Stonespar collection offers designers four premixed colour blends from our collection of Indian Sandstones. Blends of three colours have been combined to create distinctive paving planks that can be used up to marketplace loading giving the perfect solution for mixed-use urban spaces.

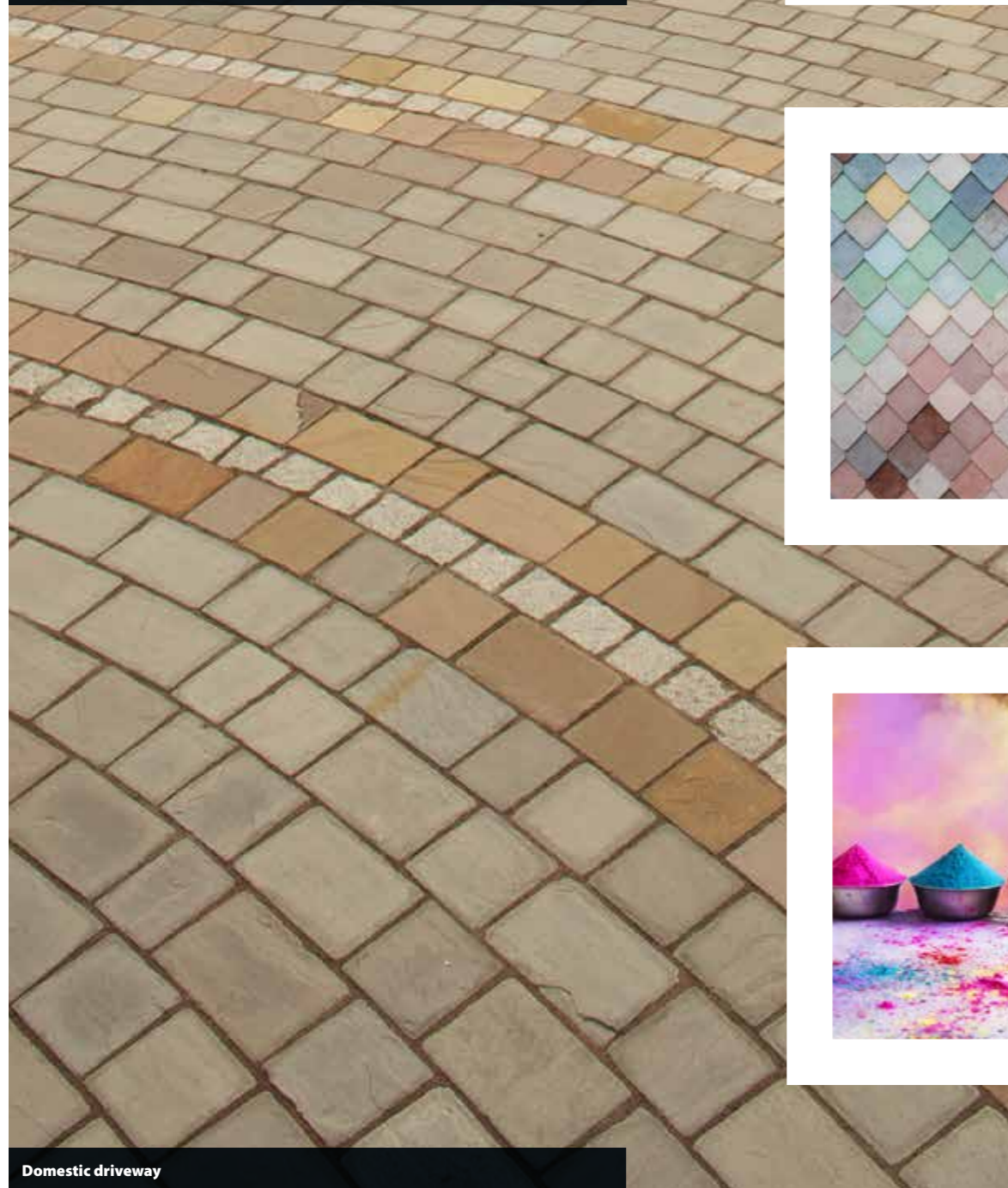

Domestic driveway

Timekeepers Square | Salford

INSPIRE WITH BLENDS

A development of 36 townhouses, Timekeepers Square is situated in the historic Adelphi/Bexley Square conservation area in Salford with the iconic Grade II listed St Phillips Church, at its centre.

The primary objective of the scheme was to blend the old with the new, and re-establish the area's historic street layout, which had long since disappeared, reinstating a natural flow of the scheme's streets towards the area's historic centrepiece.

Therefore, in order to create a clearly defined route towards the church, a paving solution that was sympathetic to the area's rich history, but that also complemented the neighbouring contemporary styled Georgian terraces, was required.

Marshalls' Vasanta blend Sandstone was selected as the ideal choice for the project. The contemporary linear plank style created a wide, open feel to the pedestrian boulevard, creating the perfect approach to St Phillips Church, and an inviting walkway for residents and visitors alike.

The Vasanta Blend of colours is inspired by the first Spring sunshine of the year. It mixes a beige base colour with a range of other shades of pale greys to warm buffs that create a truly unique blend.

This gentle colour blend and subtle variations throughout the natural stone provided a harmonious balance between traditional and contemporary which mirrored the historic areas redevelopment. Throughout the space, striking bespoke water jet cut flags have been included in the pedestrianised areas, capturing local scenes made famous by the eminent Salfordian artist LS Lowry.



Inspire with textures

The use of an appearance, feel or consistency of a material to create effects or contrasts for a design. The texturing of stone affects its pigment; from a subtle shade variation to a complete change of colour. The most dramatic changes tend to be on the stronger coloured stones such as blacks and strong reds but then buffs and beiges are significantly altered by flame texturing.

Different textures can also be a way of creating subtle banding within an element without having to try and mould two stones together. Heavier textures could be used to determine walking routes, a warning around ground mounted features such as fountains and hills or even as a deterrent for skateboarders.

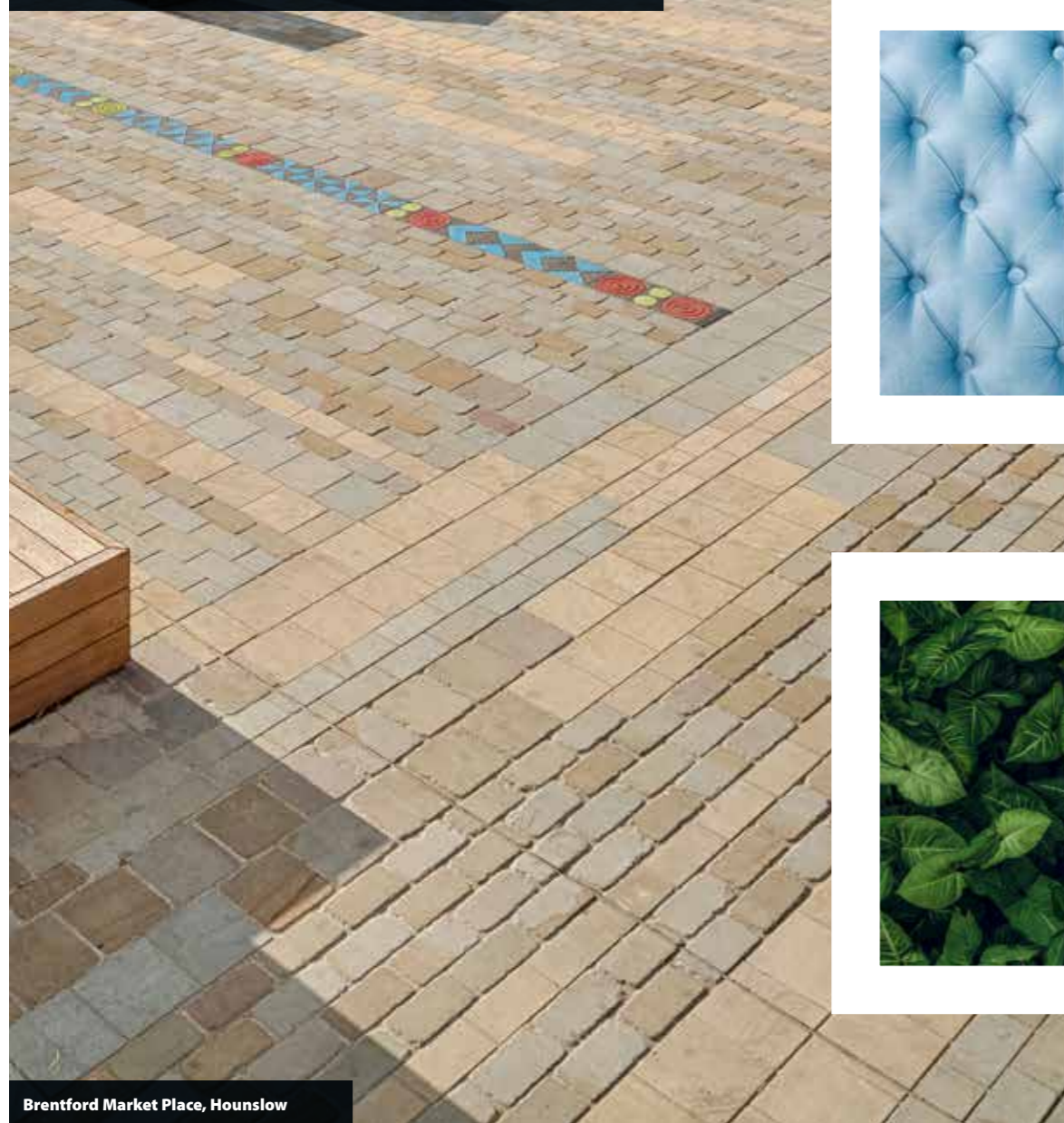
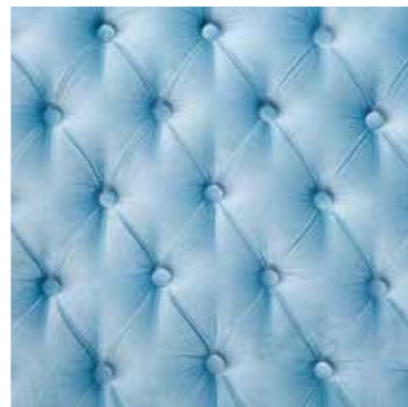

Brentford Market Place, Hounslow

Brentford Market Place | London

INSPIRE WITH TEXTURES

CASE STUDY

Marshall's Scoutmoor and Moselden Yorkstones, renowned for their durability and aesthetics, were selected in different colours and finishes by architects Kinnear. Their vision was to create interesting linear design effects by blending the original and new materials to achieve the desired mix and colour variation. This was the first scheme of its kind to mix Yorkstones in this way.

Different surface finishes can enhance the colour differences and add to the overall aesthetic appeal. The tumbled-finished stone provides an antiqued, distressed look, reminiscent of old Yorkstone cobbles and perfectly complements the look of the existing stone. The diamond sawn finish brings the scheme up-to-date, with sleek contemporary lines. Both finishes have excellent slip-resistant properties.

It was initially estimated that only a small amount of the existing Yorkstone could be reused, but on inspection of the up-lifted stone it was revealed that approximately 70% could be suitable for reuse in the scheme, highlighting the inherent durability of this material.

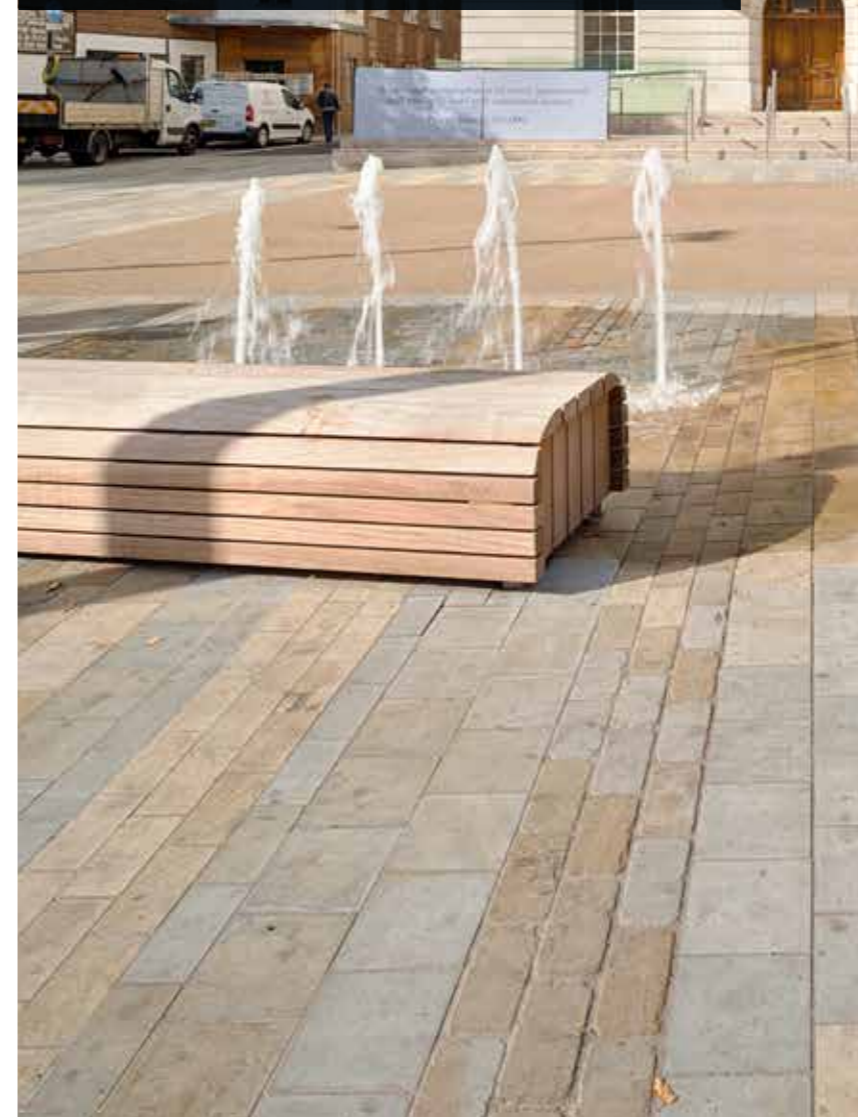

Inspire with sizes

Use of size or changes in size to emphasise a space or a detail has the ability to create interest in a landscape.

Random lengths in Sandstones are prime examples but mixing sizes in any material can achieve a unique aesthetic or a specific pattern. Using mixed sizes together can also create a changing narrative or even emphasise a detail.

People automatically assimilate smaller element sizes for the trafficked areas and larger flag sizes in the pedestrian areas. Generally this works in terms of performance as well but it also gives the opportunity to break the norm and challenge people and usage by using changing sizes or alignment in some way.



International Quarter London

International Quarter London

INSPIRE WITH SIZES

CASE STUDY

International Quarter London (IQL) is an exciting new space in Stratford dubbed as London's new destination for progressive business. The space will eventually be home to over 25,000 people occupying four million sq. ft. of grade A office accommodation.

Gustafson Porter + Bowman's landscape design has created intrigue through the use of angular zones comprising of precision cut rhombus shaped sandstone. Alternating sections of cream Laurel Bank sandstone and buff / brown Brownridge sandstone are intersected by bands of grey Thornlake sandstone, black Vega granite and Stainless Steel strips.

The remarkable diamond shaped sandstone had to be meticulously cut to maintain the crisp linear flow of the space. In contrast to the sharp angles of the laying pattern, the outer edges used to create the planted areas were softer, utilising rounded contours for a unique finish.





CAITHNESS
SCOUTMOOR
SHEPLEY HILL

BRITAIN IS BLESSED WITH A FINE SELECTION OF NATURAL SANDSTONES; AND IS ONE OF THE MAJOR SOURCES OF EUROPEAN NATURAL STONE.



CAITHNESS SANDSTONE

Primarily dark grey to black, Marshalls' Caithness Sandstone can be used across a variety of applications.

Produced to the highest standards at a facility that is ISO9001 accredited as well as ISO14001 Environmentally accredited and BS EN 45001 Health & Safety accredited. All Marshalls Sandstones are fully tested to the appropriate standards and are CE marked in accordance with the latest legislation.

Available Applications: Paving & Setts, Kerbs

TECHNICAL DATA		
DENSITY	2680 kg/m ³	Mean value to EN 1936 : 2006
WATER ABSORPTION	0.1%	Mean value to EN 13755 : 2008
FLEXURAL STRENGTH	38.3 Mpa	Mean value to EN 12372 : 2006

ETHICAL RISK SCORE
OUR SCORE: **4.8**
CLUSTER SCORE: **3.8**

FOR FURTHER INFORMATION ON THE ERI, PLEASE VISIT WWW.MARSHALLS.CO.UK/ERI



SCOUTMOOR YORKSTONE

Scoutmoor Yorkstone is a blue grey to brown coloured stone popular in projects across the UK thanks to its impressive technical performance. The strongest type of Yorkstone available in the UK, it is perfect for paved applications thanks to its strength, durability and class-leading slip resistance. Suitable for both pedestrian and trafficked areas, it's a reliable and hardwearing addition to any commercial or public space.

Produced to the highest standards at a facility that is ISO9001 accredited as well as ISO14001 Environmentally accredited and BS EN 45001 Health & Safety accredited. All Marshalls Yorkstones are fully tested to the appropriate standards and are CE marked in accordance with the latest legislation.

Available Applications: Paving & Setts, Kerbs, Tactile, Water Management, Bespoke, Furniture, Artwork

TECHNICAL DATA		
DENSITY	2538 kg/m ³	Mean value to EN 1936 : 2006
WATER ABSORPTION	1.86%	Mean value to EN 13755 : 2008
FLEXURAL STRENGTH	22.2 Mpa	Mean value to EN 12372 : 2006

ETHICAL RISK SCORE
OUR SCORE: **4.8**
CLUSTER SCORE: **3.8**

FOR FURTHER INFORMATION ON THE ERI, PLEASE VISIT WWW.MARSHALLS.CO.UK/ERI

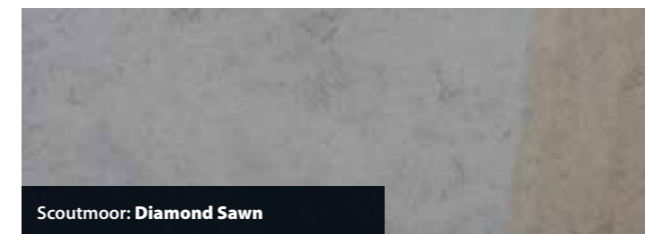

British Yorkstone
SHEPLEY HILL



SHEPLEY HILL YORKSTONE

Shepley Hill Yorkstone is a consistent blue stone combing natural high slip resistance with strength, making it suitable for both pedestrian and trafficked areas.

Produced to the highest standards at a facility that is ISO9001 accredited as well as ISO14001 Environmentally accredited and BS EN 45001 Health & Safety accredited. All Marshalls Yorkstones are fully tested to the appropriate standards and are CE marked in accordance with the latest legislation.

Available Applications: Paving & Setts, Kerbs, Tactile

TECHNICAL DATA		
DENSITY	2379 kg/m ³	Mean value to EN 1936 : 2006
WATER ABSORPTION	2.9%	Mean value to EN 13755 : 2008
FLEXURAL STRENGTH	13.6 Mpa	Mean value to EN 12372 : 2006

ETHICAL RISK SCORE

OUR SCORE: **4.8**

CLUSTER SCORE: **3.8**

FOR FURTHER INFORMATION ON THE ERI, PLEASE VISIT WWW.MARSHALLS.CO.UK/ERI



Shepley Hill: **Capital**



Shepley Hill: **Diamond Sawn**

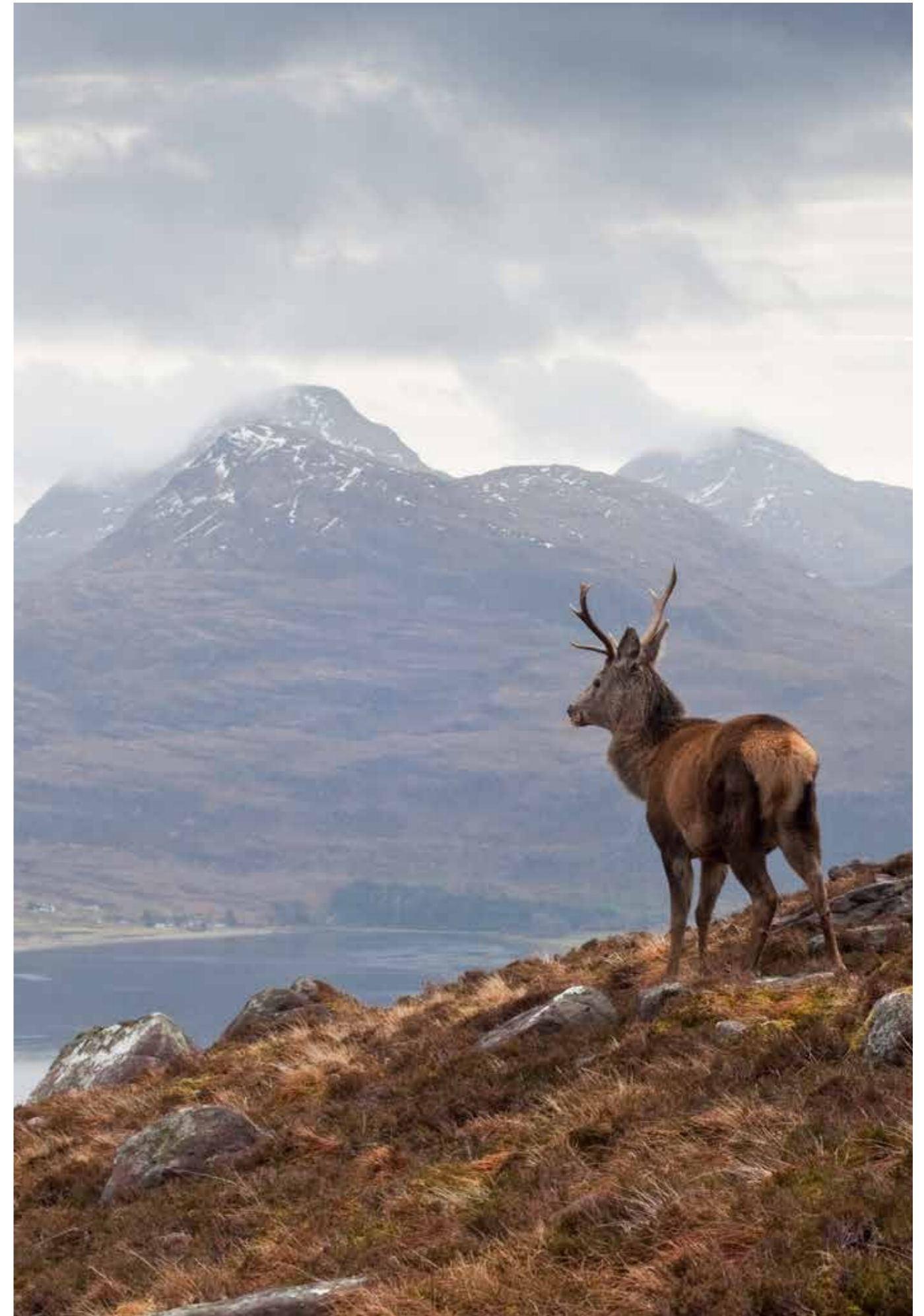



indian sandstone

S A N D S T O N E C O L L E C T I O N



BRACKENDALE
BROWNRIDGE
LAUREL BANK
SANDER RED
THORNLAKE

OUR INDIAN SANDSTONE RANGE CONTAINS SOME OF THE HIGHEST TECHNICALLY PERFORMING STONES IN THE WORLD, WITH A FINE SELECTION OF COLOURS FOR TRUE CUSTOMISATION.

Indian Sandstone **BRACKENDALE**



BRACKENDALE SANDSTONE

Brackendale is a warm buff, lightly textured Sandstone paving that has some very subdued banding.

Extremely strong, it offers all-round high performance and is an ideal choice for mixed-use areas given its ability to carry quite high loads. Suitable for both pedestrian and vehicular trafficked areas, it is supplied with a blasted finish.

All Marshalls Sandstones are fully tested to the appropriate standards in the UK and are CE marked in accordance with the latest legislation.

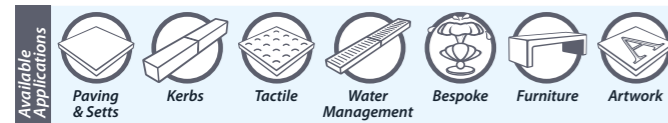

TECHNICAL DATA

DENSITY	2552 kg/m ³	Mean value to EN 1936 : 2006
WATER ABSORPTION	1.2%	Mean value to EN 13755 : 2008
FLEXURAL STRENGTH	27.5 Mpa	Mean value to EN 12372 : 2006

ETHICAL RISK SCORE

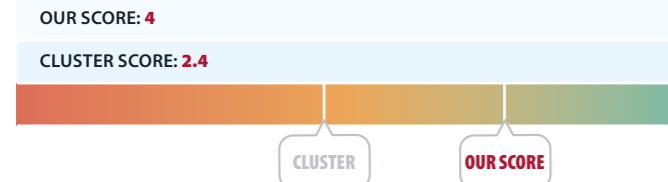

FOR FURTHER INFORMATION ON THE ERI, PLEASE VISIT WWW.MARSHALLS.CO.UK/ERI



Brackendale, Blasted



Brackendale: Blasted



Brackendale: Clear Blast



Brackendale: Flamed



Brackendale: Bush Hammered & Brushed



Indian Sandstone **BROWNRIDGE**

BROWNRIDGE SANDSTONE

Brownridge is a subtle brown coloured Sandstone.

Its strength and durability for which sandstone is traditionally renowned combined with its non-slip properties makes it an excellent choice for pedestrian and trafficked areas. Supplied with a blasted top surface to enhance slip resistance and colour.

All Marshalls Sandstones are fully tested to the appropriate standards in the UK and are CE marked in accordance with the latest legislation.

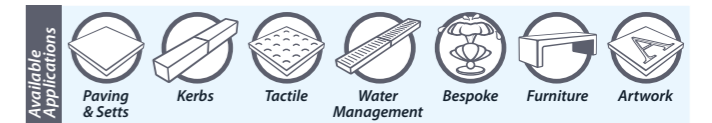

TECHNICAL DATA

DENSITY	2590 kg/m ³	Mean value to EN 1936 : 2006
WATER ABSORPTION	1%	Mean value to EN 13755 : 2008
FLEXURAL STRENGTH	37.5 Mpa	Mean value to EN 12372 : 2006

ETHICAL RISK SCORE

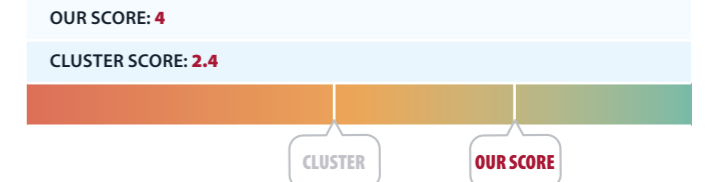

FOR FURTHER INFORMATION ON THE ERI, PLEASE VISIT WWW.MARSHALLS.CO.UK/ERI



Brownridge, Blasted



Brownridge: Blasted



Brownridge: Clear Blast



Brownridge: Flamed



Brownridge: Bush Hammered & Brushed

Indian Sandstone
LAUREL BANK



Indian Sandstone
SANDER RED

LAUREL BANK SANDSTONE

Laurel Bank is an occasionally banded light buff sandstone with a light textured finish.

The stone is an ideal choice for both pedestrian and vehicular trafficked mixed-use areas due to its extremely high strength. Supplied with a blasted top surface to enhance slip resistance and colour.

All Marshalls Sandstones are fully tested to the appropriate standards in the UK and are CE marked in accordance with the latest legislation.

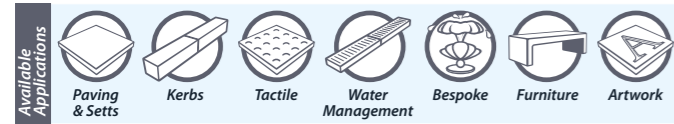

TECHNICAL DATA		
DENSITY	2520 kg/m ³	Mean value to EN 1936 : 2006
WATER ABSORPTION	1.05%	Mean value to EN 13755 : 2008
FLEXURAL STRENGTH	34 Mpa	Mean value to EN 12372 : 2006

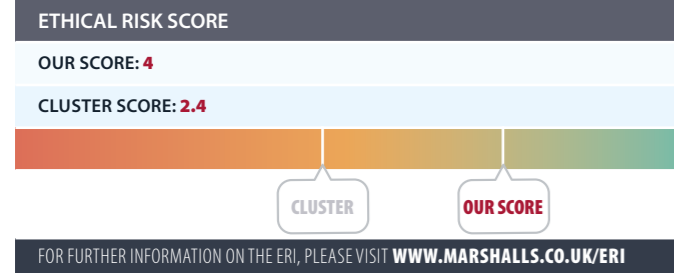

SANDER RED SANDSTONE

Sander Red is a warm red sandstone with a subtle light texture.

The stone is an ideal choice for both pedestrian and vehicular trafficked mixed-use areas due to its extremely high strength. Supplied with a blasted top surface to enhance slip resistance and colour.

All Marshalls Sandstones are fully tested to the appropriate standards in the UK and are CE marked in accordance with the latest legislation.

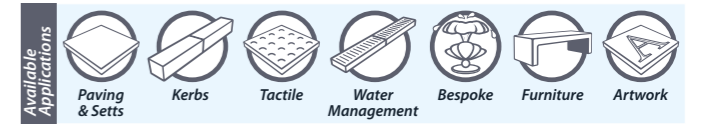

TECHNICAL DATA		
DENSITY	2552 kg/m ³	Mean value to EN 1936 : 2006
WATER ABSORPTION	1.42%	Mean value to EN 13755 : 2008
FLEXURAL STRENGTH	35.7 Mpa	Mean value to EN 12372 : 2006

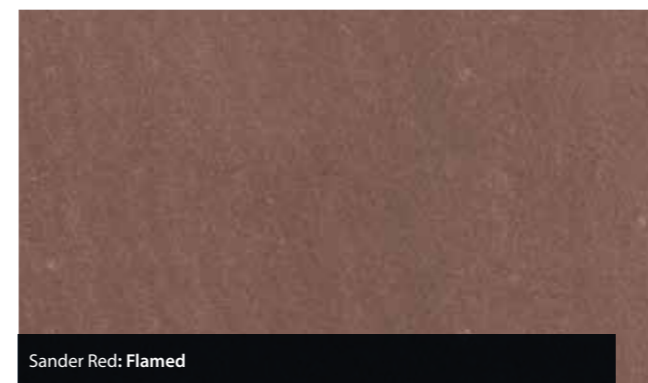
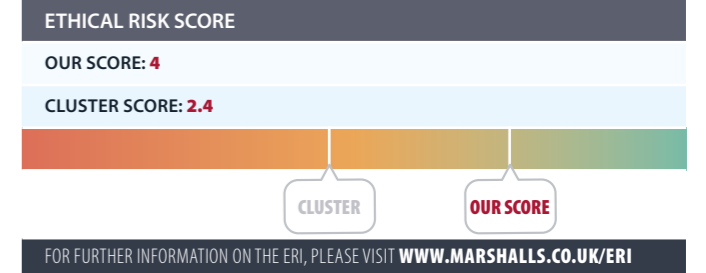

Indian Sandstone
THORNLAKE



THORNLAKE SANDSTONE

Thornlake is a grey sandstone with subtle veining.

The stone is an ideal choice for both pedestrian and vehicular trafficked mixed-use areas due to its extremely high strength. Supplied with a blasted top surface to enhance slip resistance and colour.

All Marshalls Sandstones are fully tested to the appropriate standards in the UK and are CE marked in accordance with the latest legislation.

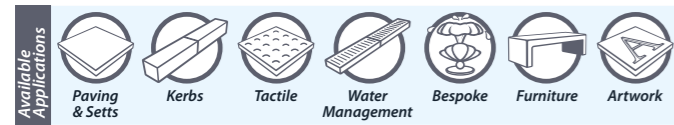

TECHNICAL DATA

DENSITY	2653 kg/m ³	Mean value to EN 1936 : 2006
WATER ABSORPTION	1.42%	Mean value to EN 13755 : 2008
FLEXURAL STRENGTH	39 Mpa	Mean value to EN 12372 : 2006

ETHICAL RISK SCORE

OUR SCORE: **4**
CLUSTER SCORE: **2.4**



FOR FURTHER INFORMATION ON THE ERI, PLEASE VISIT WWW.MARSHALLS.CO.UK/ERI



Thornlake, Blasted



Thornlake: Blasted



Thornlake: Clear Blast



Thornlake: Flamed



Thornlake: Bush Hammered & Brushed

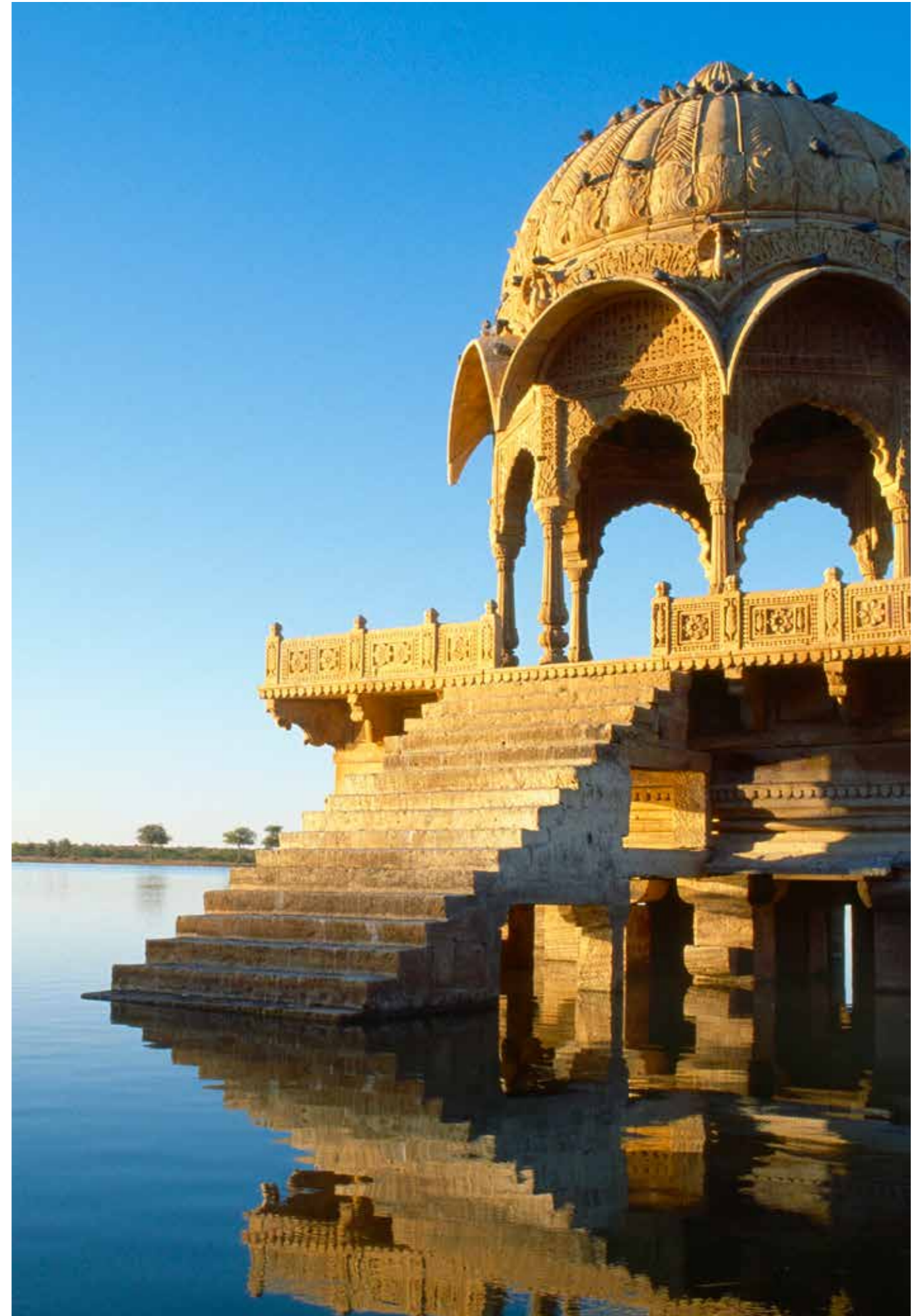

STONESPAR™

A strong, unique & durable paving, packed with creative opportunities.
Think beyond 'the normal'.



Stonespar is an innovative sandstone plank paving range available in four pre-designed colour blends, inspired by the four seasons.

Contemporary and distinctive, the 600x130x65mm planks have the ability to create an expansive outdoor space.



SANDSTONE

INSPIRATIONS CREATE SOMETHING UNIQUE WITH STONESPAR BLENDS

GRISHMA MIX

The Stonespar Grishma mix contains a blend of complementary beige and buffy hues to create a unique patterned aesthetic.

Selected from the Indian Sandstone collection, the planks come pre-mixed in the crate to ensure speedy installation and to reduce space on site.

Stonespar paving is suitable for urban areas such as town centres and commercial spaces. Their non-slip properties make them ideal for pedestrianised areas while they can also withstand occasional traffic, such as in spaces where delivery and emergency vehicles require access.

- ✓ Contemporary plank format
- ✓ Strong and durable sandstone
- ✓ Suitable for occasional traffic
- ✓ Pre-mixed for easy installation
- ✓ Ethically sourced stone

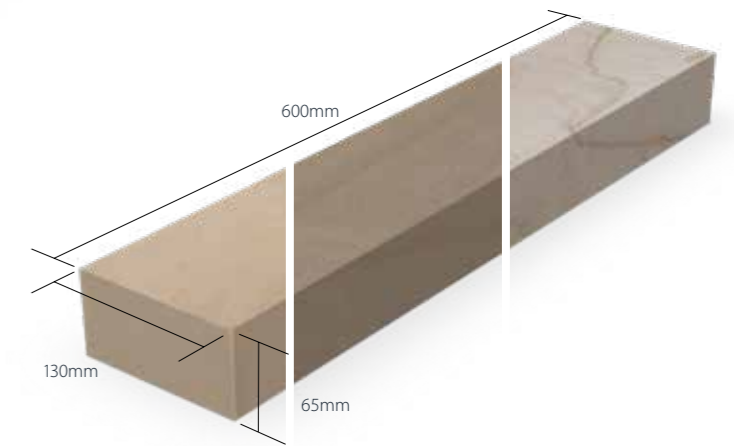

Please refer to the Indian Sandstone Collection for more information on individual stones.

CREATE SOMETHING UNIQUE WITH STONESPAR BLENDS

SANDSTONE

INSPIRATIONS

CREATE SOMETHING UNIQUE WITH STONESPAR BLENDS



HEMANT MIX

The Stonespar Hemant Mix is a blend of complementary greys, browns and beiges that creates a non-uniform look to add visual interest.

Selected from the Indian Sandstone collection, the planks come pre-mixed in the crate to ensure speedy installation and to reduce space on site.

Stonespar paving is suitable for urban areas such as town centres and commercial spaces. Their non-slip properties make them ideal for pedestrianised areas while they can also withstand occasional traffic, such as in spaces where delivery and emergency vehicles require access.

- ✓ Contemporary plank format
- ✓ Strong and durable sandstone
- ✓ Suitable for occasional traffic
- ✓ Pre-mixed for easy installation
- ✓ Ethically sourced stone

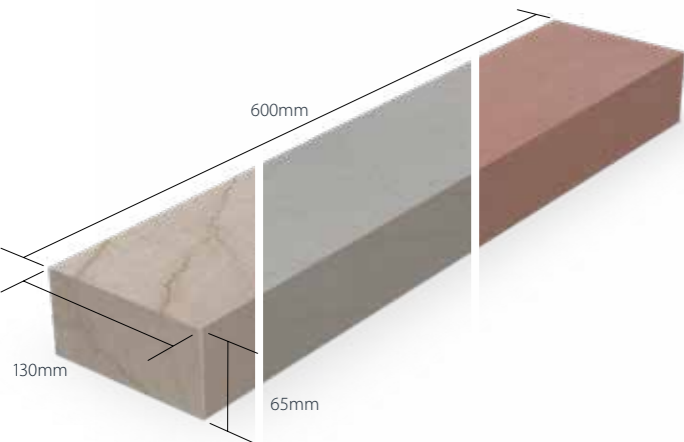

Please refer to the Indian Sandstone Collection for more information on individual stones.

CREATE SOMETHING UNIQUE WITH STONESPAR BLENDS



SANDSTONE
INSPIRATIONS
CREATE SOMETHING UNIQUE WITH STONESPAR BLENDS

SHARAD MIX

Stonespar Sharad mixes the base colour of Brownridge with lighter tones of buff and an accent of red to create a unique patterned aesthetic.

Selected from the Indian Sandstone collection, the planks come pre-mixed in the crate to ensure speedy installation and to reduce space on site.

Stonespar paving is suitable for urban areas such as town centres and commercial spaces. Their non-slip properties make them ideal for pedestrianised areas while they can also withstand occasional traffic, such as in spaces where delivery and emergency vehicles require access.

- ✓ Contemporary plank format
- ✓ Strong and durable sandstone
- ✓ Suitable for occasional traffic
- ✓ Pre-mixed for easy installation
- ✓ Ethically sourced stone

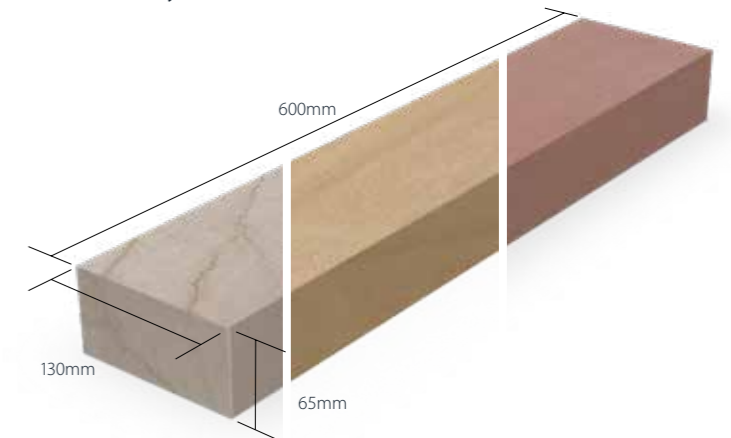

Please refer to the Indian Sandstone Collection for more information on individual stones.

CREATE SOMETHING UNIQUE WITH STONESPAR BLENDS

SANDSTONE

INSPIRATIONS

CREATE SOMETHING UNIQUE WITH STONESPAR BLENDS



VASANTA MIX

The Vasanta Mix blends a base colour of Brackendale with shades of light buff and grey to create a unique colour blend.

Selected from the Indian Sandstone collection, the planks come pre-mixed in the crate to ensure speedy installation and to reduce space on site.

Stonespar paving is suitable for urban areas such as town centres and commercial spaces. Their non-slip properties make them ideal for pedestrianised areas while they can also withstand occasional traffic, such as in spaces where delivery and emergency vehicles require access.

- ✓ Contemporary plank format
- ✓ Strong and durable sandstone
- ✓ Suitable for occasional traffic
- ✓ Pre-mixed for easy installation
- ✓ Ethically sourced stone

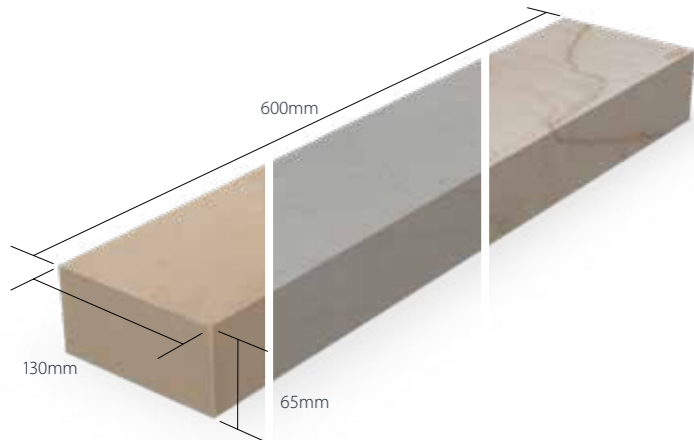

Please refer to the Indian Sandstone Collection for more information on individual stones.

CREATE SOMETHING UNIQUE WITH STONESPAR BLENDS



Marshalls plc
Landscape House
Lowfields Business Park
Elland HX5 9HT
United Kingdom

T: 03704 11 22 66
E: natstone.sales@marshalls.co.uk

marshalls.co.uk/naturalstone

Marshalls
Creating Better Spaces